

## 5. Correct usage of NOK O – rings

### 5-1. How to choose the thickness of O – ring

Figure –2 shows the relation between the thickness and compressive permanent set of O – ring. In case of certain compression ratio, the larger the cross – section diameter, the less the permanent set, so larger cross – section diameter O – ring has better sealing ability. In dynamic sealing, larger thickness O – ring can even prevent twist.

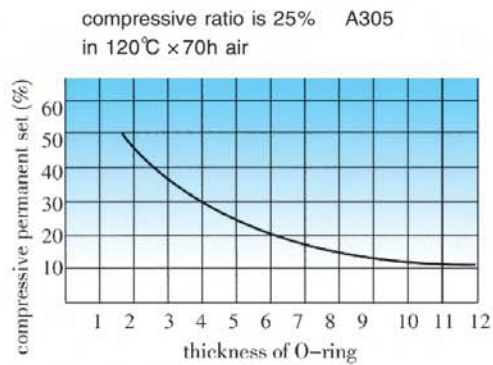

Figure-2

### 5-2. Application under high pressure

O – ring works on the base of compressive stress and sealing liquid, so the limitation of pressure should be considered. In real application, the place where O – rings installed must maintain certain pressure, while the O – rings will not be squeezed into.

So, the real pressure resistance of O – ring is determined by the relation between mechanical strength (hardness as its representative) and clearance among materials.

Figure –7 shows this relation. According to figure –7, we suggest to install back – up rings when the real pressure or clearance is beyond its limitation.

If two directions are compressed, two backup rings should be installed; if only one direction is compressed, install one backup ring at the opposite direction is enough. There are 3 kinds of backup rings: round type, beveled type and screw type. Round type backup ring provides good effect, while beveled type and screw type provide easy installation.

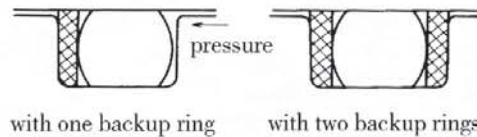

## 5-2 Application in different conditions

### ① Cylindrical surface static sealing

As the dimension tolerance combination may cause problem shown in figure -3, even adopt O-rings and grooves according to JIS standard, please pay special attention that O-rings must only be squeezed in.

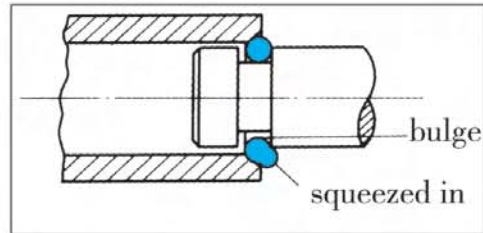

Figure -3

### ② Flat face static sealing

There are two kinds of flat face static sealing: internal pressure application, as shown in figure -4 a, and external pressure application, as shown in figure -4 b. For internal pressure application, we use external diameter for mating; for external pressure application, we use inner diameter for mating.

As damage caused by squeeze is not resulting from installation, elongation of bolts and deformation of flanges should be considered: these two parameters should be larger than in cylindrical surface static sealing. For application shown in figure -4 c, O-rings should not be used, as they can not contact the wall, and may wear or fall off as pressure varies.

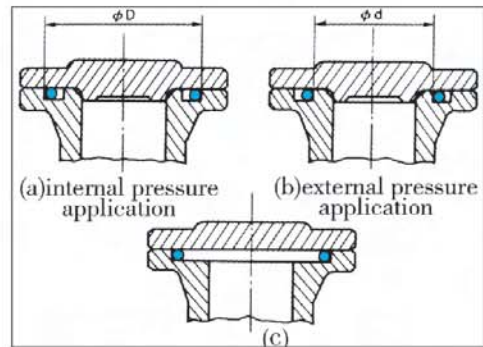

Figure -4

When inner diameter is comparatively large (large than  $\phi 150$ ) and cross-section diameter is small (less than  $\phi 3$ ), problems shown in figure -5 may happen. We should install larger thickness O-rings in this condition.

In internal pressure application, if D is comparatively small (about less than  $\phi 30$ ), the installation may be not so good, we suggest to use larger D (about 0.2 - 0.3mm larger).

### ③ Vacuum flange sealing

Application of O-ring in vacuum flange is different from normal hydraulic sealing in the following aspects:

Sealing medium in vacuum flange is air, and it is easier to leak than liquid sealing medium, so the roughness of contact surface of O-rings should be paid special attention.

If rubber material is not chose according to vacuum degree, air will exist in the material, so additive will be dispersed, and vacuum degree can not be kept. So, rubber material should be chosen according to Table 4 - 1 on page 9 and Table 4 - 2 on page 10.

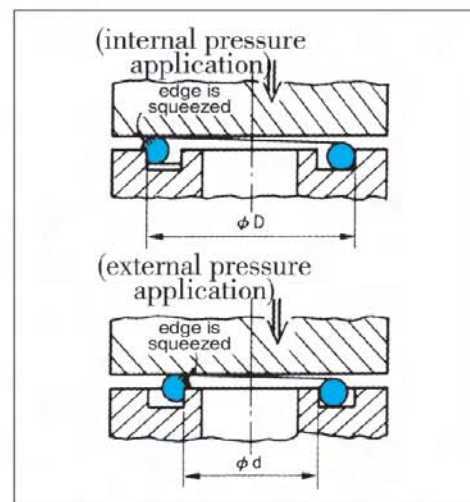

Figure -5

④ Triangle groove application

Triangle groove, also named end chamfered groove, is sometimes used to simplify machines. As shown in figure -6, O-ring is pressed from three directions, so compressive permanent set will be larger than normal groove.

Application method is shown in figure -6, as to dimension of D and d, please refer to dimension table; and dimension of G should be 1.3 - 1.4W (cross-section diameter of O-rings).

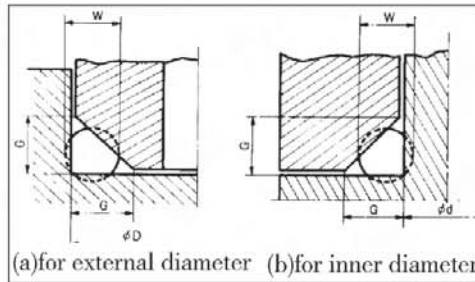

Figure -6

⑤ Pneumatic dynamic sealing

● O-ring

We suggest using JIS B and 2401 P series O-rings (NOK material symbol is A305).

● Method

1) Oil injected

- Use one O-ring for piston sealing, but two are suggested for better life time and performance.
- Use one O-ring and one dust-proofing seal for piston rod, and grease should be applied between O-ring and dust-proofing seal.

2) No oil injected

- Use two O-rings for piston sealing, grease can be applied between O-rings to serve as lubricant.
- For piston rod sealing, please refer to method for oil injected.

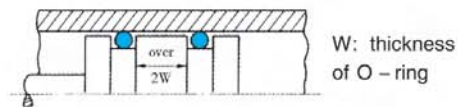

● Precautions

1) As to dimension of grooves, please refer to JIS P series dimension table.

As to fine machining, please refer to Table -5 and Table 6 on page 14. While two O-rings are used in piston rod sealing, please refer to the dimension shown in the right figure.

2) As to grease, please use NOK KLUEBER "SEALUB - S1", No. 2 lithium grease. Grease should be applied between O-rings or between O-ring and dust-proofing seal.

3) For low friction dynamic sealing, as groove dimensions are to be modified, please contact NOK directly.

## 5-4. Precautions for designing

### ① Clearance and extrusion

The extrusion in grooves is determined by pressure of sealing liquid and hard ness of rubber, whose relation is shown in figure -7 (for reference only). (The values are measured according to the pressure in cylinder before swelled; for high pressure, the diameter clearance should be 75% of these values.)

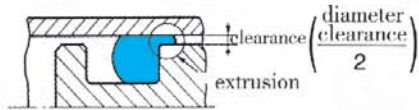

Contact NOK when designing.

### ② Compression allowance

According to sealing performance, the MIN allowance should be about 8%, and the MAX allowance should be below 30% of compressive permanent set of rubber.

Please refer to dimension table for groove dimensions when using O-rings.

### ③ Surface roughness of groove

Please refer to Table-5 for surface roughness of contact portion with O-ring.

### ④ Chamfer with housing and shaft

Please refer to Table-6 for chamfer to avoid damage from O-rings contact the cylinder and piston rod edge. And we suggest that the L should be larger than (G + b) to prevent the O-ring be trapped by the shaft.

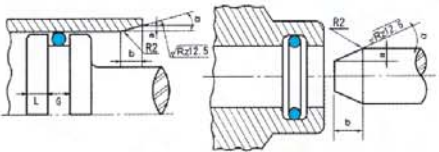

In piston rod sealing F condition, the pressure releasing hole in sliding part of O-ring must face down, so the O-ring will not be blocked by the hole. For chamfer, please refer to figter - 8.

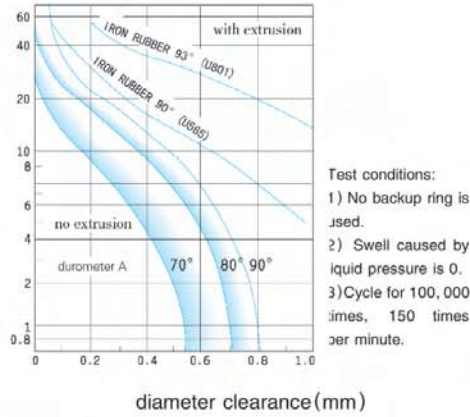

Figure -7 limitation of extrusion

Table -5 Surface roughness of groove

portion	application	pressure		surface roughness	
		no pulse	with pulse	Ra	Rz
side wall of groove and bottom	static sealing	flat face	3.2	12.5	
		cylindrical face	1.6	6.3	
	dynamic sealing	with backup ring	1.6	6.3	
		without backup ring	0.8	3.2	
contacting face of O-rings to machines	static sealing	no pulse	1.6	6.3	
		with pulse	0.8	3.2	
	dynamic sealing	—	0.4	1.6	
chamfer of O-ring installation portion	—	—	3.2	12.5	

\*Rz MAX allowance

Table -6 dimension of chamfer

nominal size		a, MIN	b for 15°/30°	
JIS	JASO			
P 3 ~P10	1003 ~1035	0.9	3.4	1.6
P 10A ~P22	2010 ~2071	0.9	3.4	1.6
P 22A ~P50	3022 ~3150	1.1	4.1	1.9
P 48A ~P150		1.3	4.9	2.3
P 150A ~P500		1.5	5.6	2.6
G 25 ~G145	3025S ~3145S	1.1	4.1	1.9
G 150 ~G500		1.3	4.9	2.3
NOK S standard S 3 ~S150		0.9	3.4	1.6
NOK SS standard SS2 ~SS12				

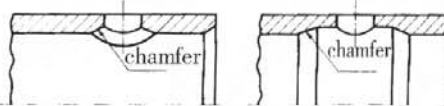

Figure - 8

## 6. Application of NOK O – rings

### 6-1. Precaution

① Use jig as shown in figur – 9 to protect O – rings when piston rod has no chamfer or screw.

When O – ring passes screws, metal sheet or belt should be used on screws so that O – rings can go smoothly.

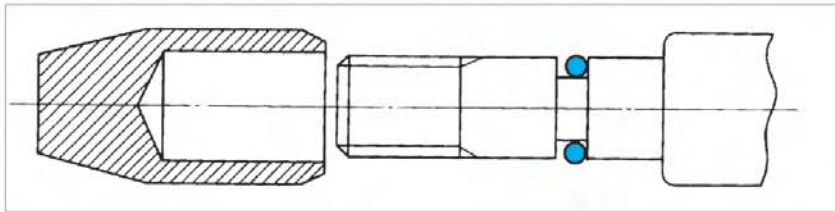

Figure – 9

- ② Do not twist O – rings when install them into grooves.
- ③ Apply sealing medium to grooves and O – rings in installation.
- ④ O – rings are not re – usable.
- ⑤ When replacing O – rings, you should replace them to the condition they were. Keep O – rings installation places clean, do not clean with detergent or gasoline, or rubber may swell.

### 6-2. Storage method of O – rings

Please pay attention to the following:

- Do not open the original package.  
Dust may damage O – rings.
- Do not expose O – rings to direct sunshine or low humidity conditions.  
Ultraviolet radiation and humid air will age rubber and plastic material.
- If the original package is open, make sure that there is no foreign particle mixed in to the O – rings.  
Use original package to store O – rings as possible.
- Do not store O – rings near high temperature source, such as boiler and stove. Heat will age rubber.
- Do not store O – rings near motors that generate ozone.
- Do not bind O – rings with a thin string and hang them on nails or wires, as this may cause O – rings to deform or damage them.
- O – rings in storage may change color, or generate white powder on their surface, this is normal, performance will not be affected.

### [Storage time]

Storage time of O – rings is shown in the following table.

This is warehouse storage time.

Product	Material	Storage time
Rubber product	polyurethane rubber(AU)	10 years
	Nitrile rubber(NBR)	10 years
	Acrylate rubber(ACM)	20 years
	Silicon rubber(VMQ)	20 years
	Fluororubber(FKM)	20 years

· Storage time in this table refers to conditions in warehouse where no direct sunshine, high temperature or high humidity exist.

## 7 Dimension table of NOK O – rings

As to dimension of groove, please refer to the dimension table for each specific model of O – ring.  
Former ARP568, AS568 series and ISO industrial universal series groove dimension is not prescribed in AS standard and ISO standard, please refer to the following setting.

Former ARP568, AS568 series } Setting of groove dimension  
ISO industrial universal series }

### ● Setting

1. compression ratio application range: 8 – 30%

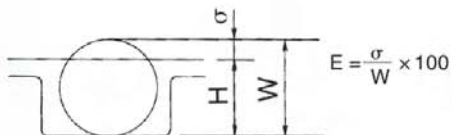

E(%) : compression ratio  
 $\sigma$  (mm) : compression allowance (= W – H)  
 W (mm) : thickness of O – ring  
 H (mm) : depth of groove

2. Filling ratio application range: max 90%, middle 75% (target value in design)

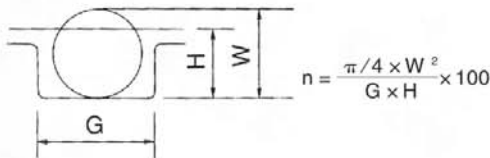

n(%) : filling ratio  
 G (mm) : width of groove  
 W (mm) : thickness of O – ring  
 H (mm) : depth of groove

※ as to groove shape, please refer to page 11 to page 14.